

Chalk Board, Large

PCM0012

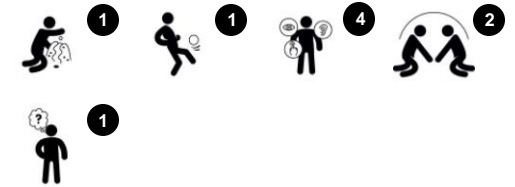

Item no.	
General Product Information	
Dimensions LxWxH	166x12x140 cm
Age group	2+
Play capacity (users)	4
Colour options	



This large chalkboard will support hours of play and learning in an outdoor learning environment or playground. The large space is plenty for many children to join in the mark making and drawing, which will help them to develop fine motor skills when drawing, and language and literacy skills when making signs. The large size supports social play, because

there is plenty of room for interaction and cooperation. Chalkboards can have direct benefits for learning, and they also enhance a variety of dramatic play scenarios, from playing school to making a sign for treasure hunting games. There are cognitive benefits to drawing and leaving your mark, because it stimulates brain development, creative thinking and thus

problem solving skills.



Data is subject to change without prior notice.

Chalk Board, Large

PCM0012

Board is made of ceramic steel. Ceramic steel has high corrosion resistance and it is completely recyclable.

Posts are made of pine wood posts pressure impregnated class AB with Tanalith E3475 according to EN335.

Panels of 19mm EcoCore™. EcoCore™ is a highly durable, eco friendly material, which is not only recyclable after use, but also consists of a core produced from 100% recycled material.

Item no.	
Installation Information	
Max. fall height	0 cm
Safety surfacing area	12,3 m ²
Numbers of installers (persons)	2
Total installation time	
Excavation volume	
Concrete volume	
Footing depth (standard)	
Shipment weight	
Anchoring options	In-ground ✓ Surface ✓
Warranty Information	



Chalk Board, Large

PCM0012

* Max fall height | ** Total height | *** Safety surfacing area

* Max fall height | ** Total height

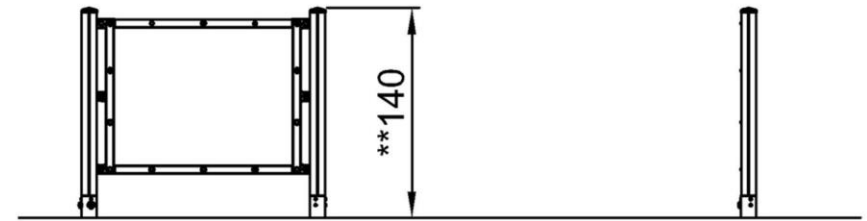
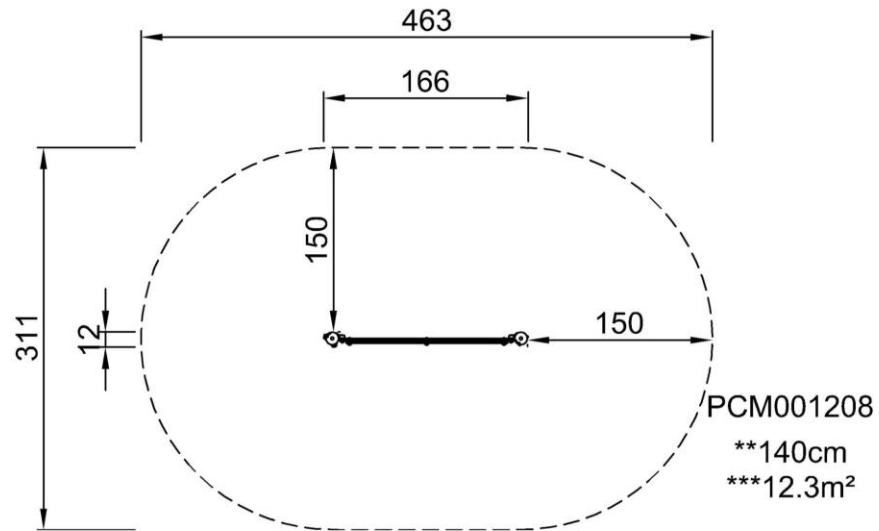

PCM001208
1:100

[Click to see 1:100 ratio TOP VIEW](#)

Chalk Board, Large

PCM0012

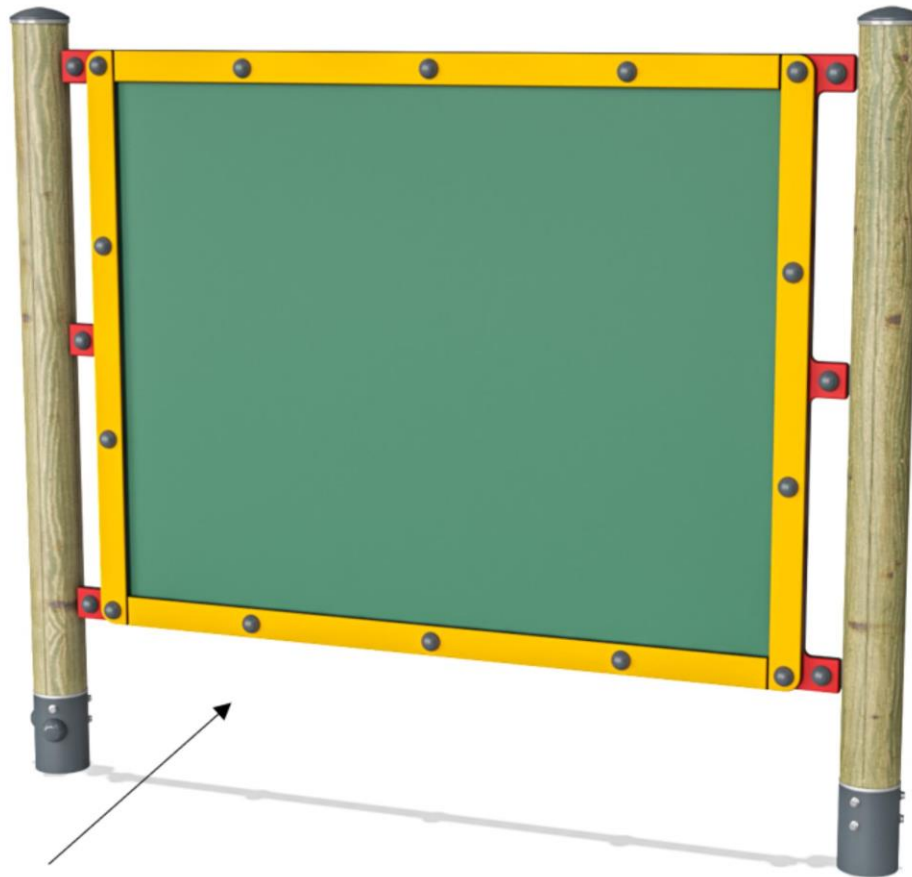

Chalk Board

Social-emotional: the two sides and width of the blackboard caters for groups of children cooperating and sharing ideas.
Cognitive: understanding of individuality and self expression. Stimulates dramatic play and thus language development.
Creative: drawing and leaving your mark stimulates brain development, creative thinking and thus problem solving skills.



Maze

Social-Emotional: communication and cooperation exploring the maze with friends.
Cognitive: stimulates memory when memorizing maze routes. Learning about perspective when looking at things at a certain distance.



Chalk Board, Large

PCM0012



PHYSICAL
Joy of movement:
motor skills, muscle, cardio
and bone density



SOCIAL-EMOTIONAL
Joy of being together:
teamwork, tolerance and
sense of belonging



COGNITIVE
Joy of learning:
curiosity, understanding of causal
relationships and knowledge of the world



CREATIVE
Joy of creating:
co-creation and experimenting
with materials



BALANCE
To balance is to stay upright when walking or standing on a surface that makes this challenging (e.g. a wobbly, inclined, or narrow surface).



HANG IN ARMS
To hang in arms is the act of carrying the body with the hands or arms, possibly to traverse to another platform or play item.



SENSORY
To sense is the act of taking in information with the sensory system: seeing, feeling, hearing or sensing with the body.



BOUNCE
To bounce is the act of bouncing on a responsive, flexible, elastic or tensile surface.



JUMP
To jump is the act of jumping up or down on a hard surface.



SLIDE
To slide is the act of moving fast downwards seated on a slide.



CLIMB
To climb is the act of moving upwards, cross-coordinating arms and legs, on a vertical or inclined surface or net.



PULL
To pull is the act of pulling an item towards you or you towards an item with one or both hands, or possibly using the entire body.



SOCIALIZE
To socialize is the act of meeting, communicating or cooperating in an activity that stimulates and facilitates social interaction.



CONSTRUCT
To construct is the act of creating new patterns, shifting items or materials to new positions or constructing with materials that can be transformed or manipulated.



PUSH
To push is the act of pushing an item away from you with one or both hands, possibly with the entire body.



SPIN
To spin involves a fast, repeated horizontal or vertical turn of the body on a piece of equipment that facilitates the movement.



CRAWL
To crawl is the movement of moving forwards or backwards, cross-coordinating arms and legs, on a horizontal or slightly inclined surface.



ROCK
To rock is the action of rocking back and forth, or sideways, on e.g. a piece of spring equipment.



SWAY
To sway is the movement of swaying back and forth, or around, lying, seated or possibly standing, in a pendulant or circular movement, e.g. on a hammock or on a rope.



DRAMATIC PLAY
Dramatic play is motivated through play items that stage a frame, place or environment for acting out make believe or role play scenarios.



ROTATE
To rotate involves a vertical or horizontal slower paced turn of the body, facilitated by a piece of equipment.



SWING
To swing is the movement of swinging back and forth, or in circular movement, seated, standing or lying, in an unhindered arc.



GLIDE
To glide is the act of moving from one point to another without shifting the feet, in a horizontal or vertical movement, in a seated, lying or standing position, letting gravity do the work.



RULES PLAY
Rules play is motivated through play items that suggest games-with-rules, cooperation and team work, e.g. tic-tac-toe, timers or ball games.



WONDER
To wonder is motivated through play items that make children need and use their logical, abstract or creative thinking skills, as well as their memory.